

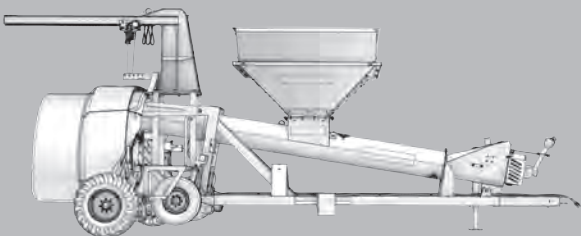

**LOFTNESS**

# **GL SYSTEM 12™**

**HD GRAIN BAG UNLOADER**  
**HD GRAIN BAG LOADER**  
**HD TRUCK UNLOADING AUGER**

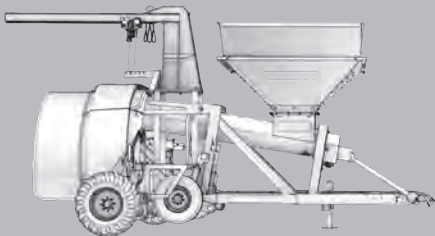
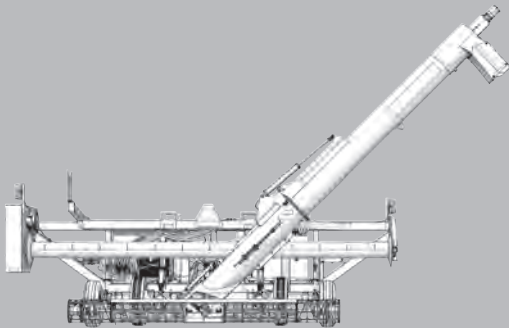
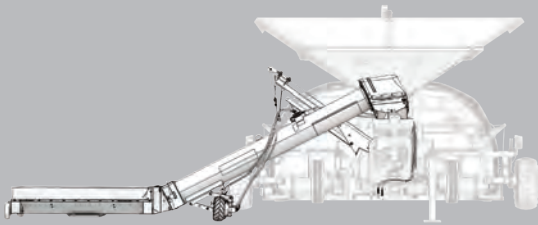

**MAXIMUM  
CAPACITY.  
MAXIMUM  
PERFORMANCE.**



# BRINGING GRAIN BAGGING PERFORMANCE TO A WHOLE NEW LEVEL



**Per linear foot, 12-foot grain bags hold approximately 75 percent more grain than 9-foot bags.**

This load capacity, combined with the high performance of the Loftness GL System 12, gives your operation the ability to quickly and confidently react to the heaviest harvest demands. It's an ideal solution to storage issues created by increasing yields, increasing storage facility expenses, harvest segregation requests and inconsistent market demands.

**LOFTNESS**   
SPECIALIZED EQUIPMENT. UNLIMITED INNOVATION.

**GRAIN LOGIX**<sup>™</sup>  
GRAIN BAG STORAGE SYSTEMS



**GL SYSTEM12™**

- HD GRAIN BAG UNLOADER**
- HD GRAIN BAG LOADER**
- HD TRUCK UNLOADING AUGER**

# THE BIGGEST BAGGER YOU CAN BUY

With the GL System 12 Grain Bag Loader (GBL 12), the innovation and engineering experts at Loftness have delivered the ultimate commercial-grade line of grain bagging equipment. Equipment with consistent, on-demand performance like this can only come from the leader in grain bagging equipment innovation – Loftness.

## // Innovative Bag Loading

The Grain Bag Loader makes it easy to install 12-foot bags, which can weigh approximately 1,000 pounds each. The grain bags are first put onto a cradle. Then, a 12-volt electric **jib crane and powered trolley system** lifts them off the ground and slides them into place over the tunnel. Working in tandem with the powered trolley system, a **bag loading tarp** greatly reduces the amount of labor required to position the bottom of the bag onto the bag pan.



## // Maximum Control

The GBL 12 provides maximum control over the grain bagging process with two 15 x 19.5-inch **Bar Tread traction tires** equipped with extra-large **automotive style disc brakes**. The unit includes a **rotary hand wheel**, which precisely applies brake pressure to both wheels simultaneously, while displaying the current pressure via a large liquid-filled gauge.

## // FEATURES

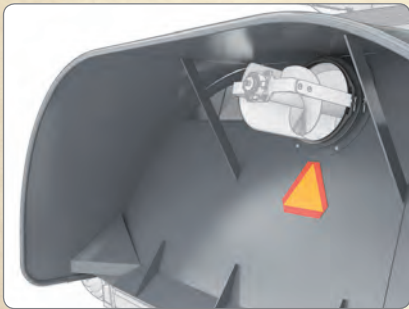

**Specialized Tunnel:** The one-piece tunnel is designed to distribute grain evenly throughout the profile of the bag.



**Transport Wheel System:** Features properly rated tires, axles and electric brake system for safe/legal transport.



**Adjustable Height:** Axle height can be consistently raised/lowered using a pin adjustment system.



**Extra Large Hopper:** An easy target to hit, which reduces potential spillage. Can be loaded from either side, or both simultaneously.

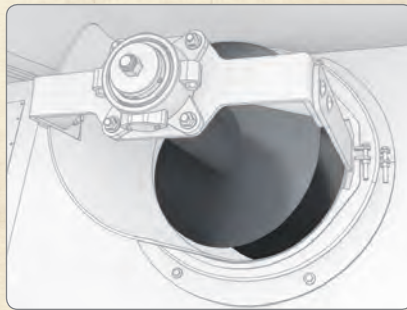

**Large Diameter Auger:** The 20-inch main discharge auger offers ¼-inch thick abrasive resistant steel flighting for long life, and delivers grain to the tunnel at up to 500 bushels per hour.



**Remote Control Operation:** A pocket-sized wireless controller operates the hoist, trolley and bag pan functions.

SEE THE FULL LIST OF  
FEATURES AND SPECS AT  
**LOFTNESS.COM**  
or call 800-828-7624

**LOFTNESS**

**GRAIN LOGIX**  
GRAIN BAG STORAGE SYSTEMS

# A LOW PROFILE HOPPER WITH HIGH TRANSFER RATES

Be ready to handle any harvest from most any trailer. The GL System 12 Truck Unloading Auger (N29114) is the perfect option for grain facilities and operations that require loading bags from grain trailers and semis. Whether dealing with bottom trap, side chutes or dump trailers, the highly controllable and high speed low-profile hopper can handle the flow — up to 200 bushels per minute.

## // Easy Operation

The **hydraulic control valve** is located on the swing hopper auger. The operator has excellent visibility and control when positioning the swing hopper under a moving or stationary truck.

## // Low-Profile Swing Hopper

Designed to rotate under the truck's discharge chute as the bag loader advances, the swing hopper is the key to successful truck unloading. The swing hopper has **twin 7-inch diameter pan augers** to move grain quickly from the truck's discharge chute into the swing auger.



## // FEATURES



**Swing Auger:** A 14-inch diameter swing auger provides easy reach and positioning control when aligning the hopper under the truck's discharge chute.

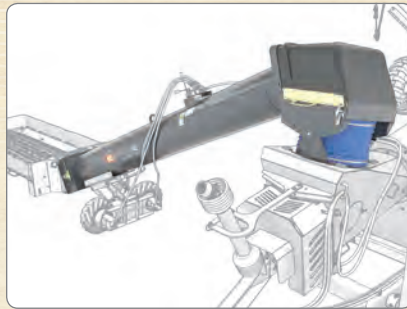

**Transition Auger:** The 14-inch diameter transition auger delivers grain to the pivot point over the base of the main auger.

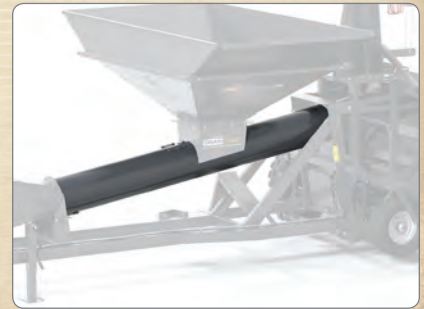

**Main Auger:** The high-speed main stationary lift auger moves grain into the hopper of the bag loader.

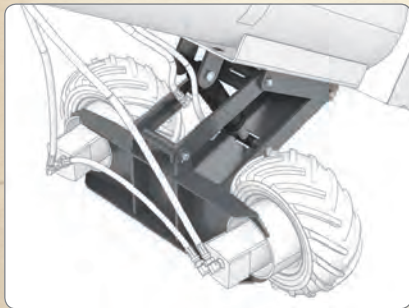

**Hopper Lift:** Used in conjunction with the drive wheels to make simple work of properly positioning the swing hopper.

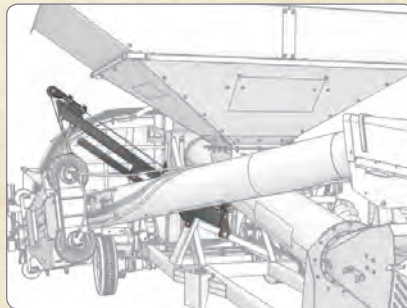

**Hopper Transport:** The swing hopper and auger are easily winched up into transport position with a cable/pulley system.

SEE THE FULL LIST OF  
FEATURES AND SPECS AT  
**LOFTNESS.COM**  
or call 800-828-7624

**LOFTNESS**

**GRAIN LOGIX**  
GRAIN BAG STORAGE SYSTEMS

# SIMPLY THE BEST UNLOADER

With the capacity to load a 1,000-bushel trailer in about 5 minutes, the GL System 12 Grain Bag Unloader (GBL 12) outperforms anything on the market, not only in speed, but also in simplicity of use, ruggedness and reliability. Stable site-to-site transportation, fast setup, easy operation and straightforward maintenance make it an indispensable part of any grain bag storage strategy.

## // Advanced Hydraulics

At the core of the hydraulic system is the **triple hydraulic pump configuration**. Each pump is dedicated to an individual task: cross feed augers, main discharge auger, and system cooling and accessories. A 70-gallon hydraulic fluid reservoir with specialized return filtration system helps reduce wear, while a **cooling system** controls oil temperature for operating efficiency. **Ground-level controls** offer convenient adjustment of all hydraulic functions.

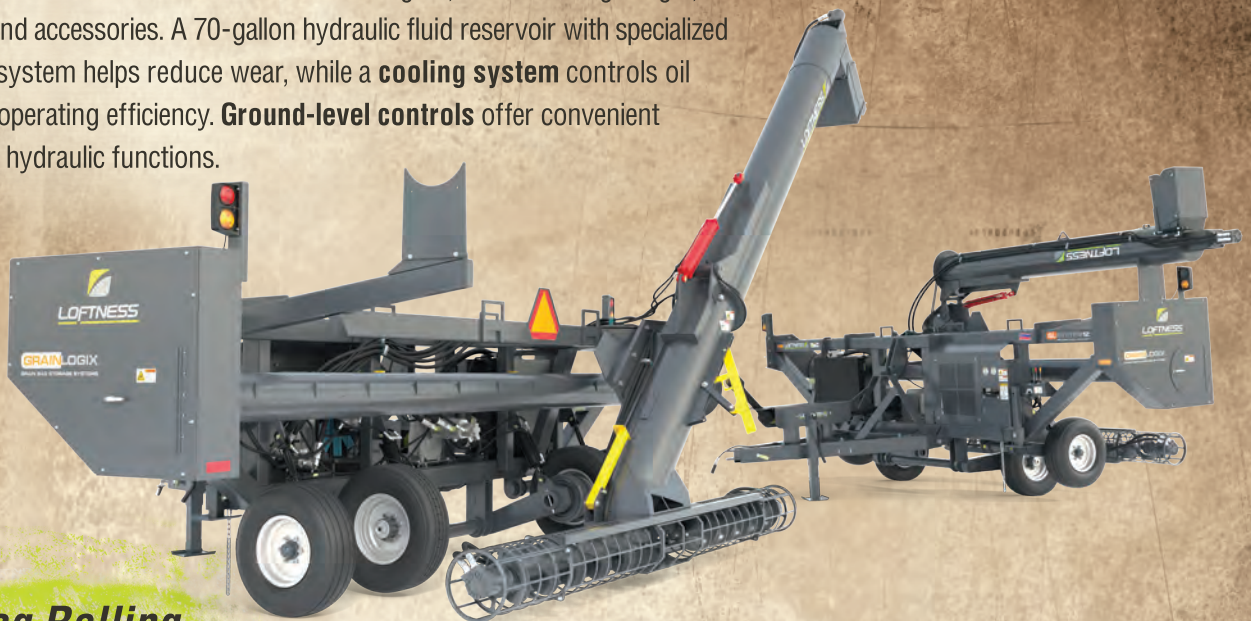

## // Easy Bag Rolling

At 19.5 feet wide, the **bag roller** has ample room for accepting flattened bags as they are emptied and rolled up. Both ends are capped with 23-inch discs, ensuring that the bag will never overrun the roller. Welded teeth spaced along the entire roller shaft ensure that the leading edge of the bag is captured securely and squarely. The **powerful hydraulic drive** further ensures successful bag unloading.



## // FEATURES

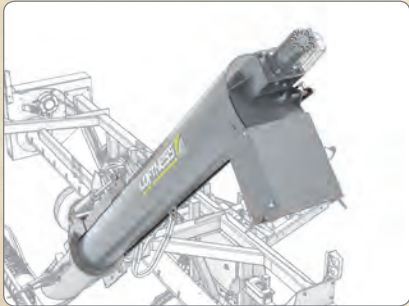

**Main Auger:** The 17-inch main auger made with 1/4-inch flighting achieves load transfer rates of 200 bushels per minute.

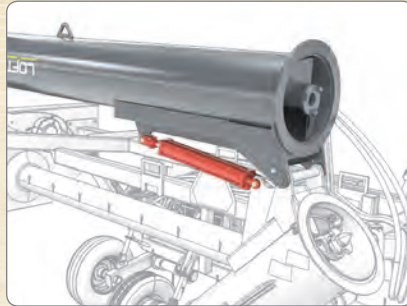

**Folding Auger:** The main auger hydraulically folds for easy storage and transportation.

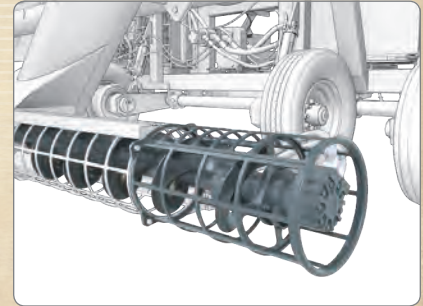

**Cross Augers:** The 12-inch cross augers feed material to the discharge auger.



**Bag Removal Clutch:** Operator can simply disengage the roller drive by hand and bag can then be rolled off the bag roller tube.

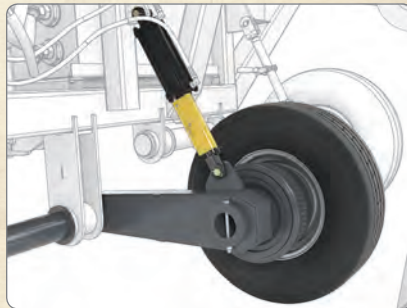

**Travel Axle:** Quickly raises the machine for transport.



**Adjustable Axle Height:** Mechanical adjustment stops provide consistent height of cross augers.

SEE THE FULL LIST OF  
FEATURES AND SPECS AT  
**LOFTNESS.COM**

or call 800-828-7624

**LOFTNESS**

**GRAIN LOGIX**  
GRAIN BAG STORAGE SYSTEMS



// Grain Bag Loader



// Truck Unloading Auger



// Grain Bag Unloader

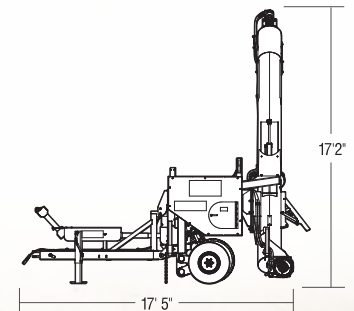
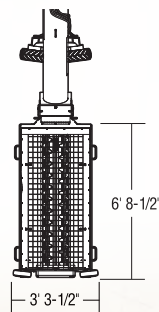
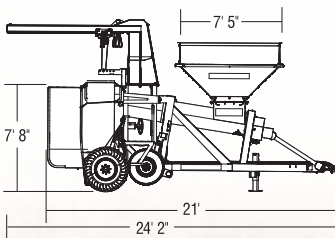
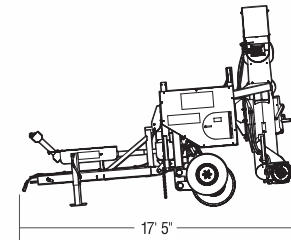
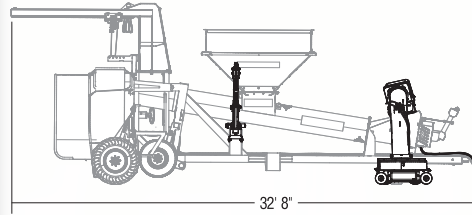
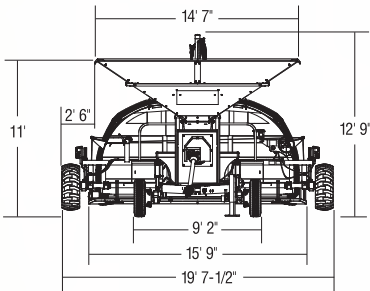
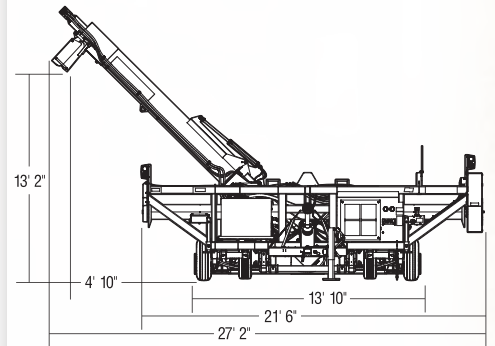
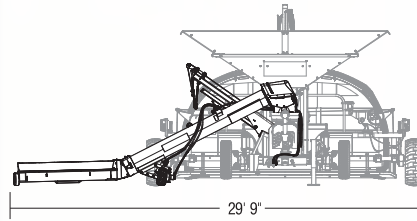
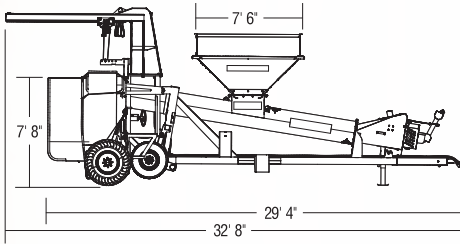
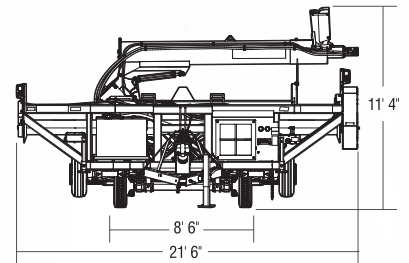
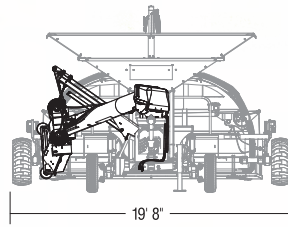
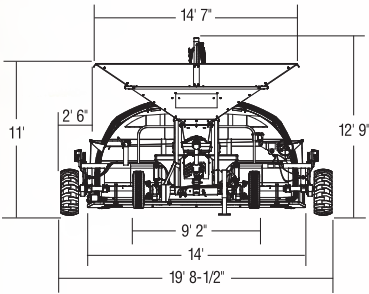

// SPECIFICATIONS

	GRAIN BAG LOADER		TRUCK UNLOADING AUGER	GRAIN BAG UNLOADER
<b>Model Number</b>	GBL 12	GBL 12C	N29114	GBU12
<b>Operating Weight</b>	11,040 lbs	9,860 lbs	1,220 lbs	11,010 lbs
<b>Operating Length</b>	32' 8"	24' 2"	32' 8"	17' 5"
<b>Operating Width</b>	19' 8-1/2"	19' 7-1/2"	29' 9"	27' 2"
<b>Operating Height</b>	12' 9"	12' 9"	12' 9"	17' 2"
<b>Travel Length</b>	32' 8"	24' 2"	32' 8"	17' 5"
<b>Travel Width</b>	19' 8-1/2"	19' 7-1/2"	19' 8"	21' 6"
<b>Travel Height</b>	12' 9"	12' 9"	12' 9"	11' 4"
<b>Hopper Dimensions</b>	7' 5" x 14' 7"	7' 5" x 14' 7"	6' 8-1/2" x 3' 1/2" x 12" (6' 8-1/2" x 3' 1/2" x 19"/with Skirting)	
<b>PTO RPM</b>	1,000	1,000	1,000 with bag loader	1,000
<b>PTO Horsepower</b>	120	120	120 with bag loader	150
<b>PTO Shaft Size/Type</b>	1-3/8 or 1-3/4	1-3/8 or 1-3/4		1-3/8 or 1-3/4
<b>PTO Driveline Type</b>	Walterscheid W2400	Walterscheid W2400		Walterscheid W2400
<b>Hydraulics GPM (required)</b>	6	6	6 with bag loader	
<b>Hydraulics PSI (required)</b>	2,000	2,000	2,000	
<b>Hydraulics Connector Type</b>	Quick Couplers	Quick Couplers	Quick Couplers	
<b>Primary Auger Size</b>	20" / 540 RPM	20" / 540 RPM	14" / 540 RPM	20" / 540 RPM
<b>Twin Hopper Auger Size</b>			7" / 750 RPM	
<b>Operation Wheels/Size/Type</b>	40" 15L-19.5 SureGrip	40" 15L-19.5 SureGrip	15" 16-6.5 Foam Filled	40" 245/70R-17.5 Implement
<b>Transport Wheels/Size/Type</b>	235/75 R17.5 Hiway	235/75 R17.5 Hiway		235/75 R17.5 Hiway
<b>Operational Braking System</b>	Hydraulic Disc	Hydraulic Disc		
<b>Transport Braking System</b>	Electrical Trailer Brakes	Electrical Trailer Brakes		Electrical Trailer Brakes
<b>Transfer Capacity</b>	30,000 Bushels / hr	30,000 Bushels / hr	30,000 Bushels / hr	12,000 Bushels / hr
<b>Bag Diameter</b>	12' Bags	12' Bags	12' Bags	12' or 10' Bags
<b>Max. Bag Length</b>	500'	500'	500'	500'
<b>Pump Drive Gearbox</b>				125 hp Step Up
<b>Pumps</b>				Triple Gear Pump
<b>Controls</b>				On/Off Valves for Auger  Stack Valve for Auxiliary Function



# LOFTNESS

SPECIALIZED EQUIPMENT. UNLIMITED INNOVATION.

## GRAIN BAG STORAGE SYSTEMS FROM LOFTNESS

**GL SYSTEM 10 XL**  
GRAIN BAG LOADER



**GL SYSTEM 10**  
GRAIN BAG UNLOADER  
GRAIN BAG LOADER  
TRUCK UNLOADING AUGER



**GL SYSTEM 12**  
HD GRAIN BAG UNLOADER  
HD GRAIN BAG LOADER  
HD TRUCK UNLOADING AUGER



// GRAIN BAGGING

// CROP SHREDDERS

// SNOW BLOWERS

// VEGETATION MANAGEMENT

**GL SYSTEM 12**  
HD GRAIN BAG UNLOADER  
HD GRAIN BAG LOADER  
HD TRUCK UNLOADING AUGER

Call us or ask your local Loftness Dealer about the Loftness GrainLogix System 12.



Loftness Specialized Equipment  
P.O. Box 337  
Hector, Minnesota 55342 USA

Toll Free US & Canada: 800-828-7624  
International 320-848-6266  
email: [info@loftness.com](mailto:info@loftness.com)  
[www.loftness.com](http://www.loftness.com)  
[www.grainlogix.com](http://www.grainlogix.com)

Specifications, data, and pricing information herein is subject to change without notice. Walterscheid and SureGrip are trademarks of their respective companies. GrainLogix, GL System10, GL System10 XL, GL System12 are trademarks of Loftness Corporation.

L100712- GL Sys 12 - 07/15